



A Series

L o u d s p e a k e r s

Performance

Driven

Technology

& Design

 **Boston**
acoustics®



Boston Acoustics A Series Design

Boston Acoustics creates all its speakers following the Play Smart approach to product design – sensible, useful, smart design features combined with contemporary styling, backed up by Boston’s 30+ years of speaker design heritage and great sound. The new A Series continues the Play Smart approach, and harkens back to the famous sound and value of Boston’s original A Series of the late 1970s and 80s.

This paper covers technical details of the design and manufacturing of the A Series: Boston Acoustics developed the A Series using the most advanced measurement methods and simulation software, incorporated innovative materials and fabrication methods, and confirmed the design by ear in focused listening sessions by skilled listeners using all types of music.

What Makes Good Sound?

Boston Acoustics speakers are designed for flat octave-to-octave frequency response (meaning all notes are produced with a consistent loudness), low distortion (meaning the sound is not being damaged), and high power handling (delivering the full dynamic range from soft to loud). When optimized, these three combine to deliver a three dimensional image and natural sound balance. And to meet these specific objectives, Boston engineers have three primary design elements – drivers, cabinet, and crossover.

Boston engineers also have an arsenal of state-of-the-art analysis tools to optimize acoustic performance. Perhaps the most important is the Klippel R&D System. Klippel analysis uses a test signal that simulates the requirements of actual musical sound. With the Klippel system, Boston engineers can identify harmonic distortion and intermodulation distortion occurring in individual components within the drivers (such as suspensions, magnets, cones) and systematically modify the design to reduce those distortions.

A Laser Vibrometer is used to scan the surface of an object, such as a cone or cabinet, showing resonances in real time. These resonances often are the source of reduced clarity in music, so such a system is critical for optimizing this clarity. And Boston Acoustics has been a pioneer in the use of Finite Element Analysis / Boundary Element Analysis simulation software – this FEA/BEA software allows the precise calculation of complex speaker behavior by breaking a complex mathematical model into literally millions of small computer calculations. Such a tool permits the driver design engineer to test many options and shapes even before building the first prototype, giving a tremendous head start in the pursuit of great sound.



Driver Design

The speaker drivers – woofers, midranges, and tweeters – are the sonic devices that translate electrical impulses from an amplifier into sound. The best driver designs make this translation with great precision, resulting in the most natural sound. These speaker elements are made up of magnetic motors (wound wire coils and magnets) that use electromagnetic force to generate motion, and a lightweight cone or dome that in turn moves air.

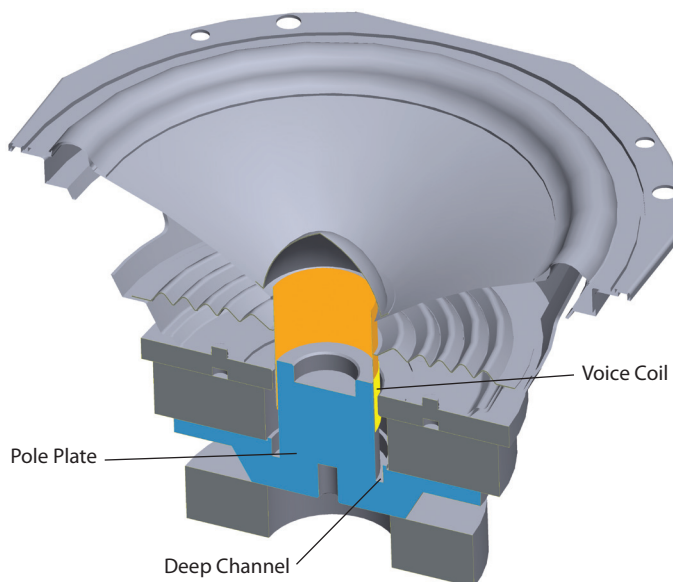

A Series woofers use Deep Channel® Design (DCD) magnet structures, optimized through the use of FEA software to open up room for maximum woofer movement (permitting higher output and greater dynamics) while eliminating any sacrifice of magnetic strength. In fact, the FEA analysis process delivers greater magnetic energy and thermal dissipation, increasing the sensitivity of the speaker and long term reliability.

A Series speaker cones are polypropylene impregnated with ceramic and glass fibers. These additives increase the strength and the stiffness of the cones and together enhance the precision of the cone's response to the voice coil's movement. The ceramic and glass fibers also serve to deaden the cone and reduce extraneous vibration modes, resulting in a cleaner sound. The exact mixture was selected by technical analysis and confirmed by listening.

Boston Acoustics developed a unique interior curve shape for the cones, a shape that gives the smoothest frequency response for the chosen stiffness and damping of the cone material. The cones are injection molded in a machined steel molding tool, a technique that insures 100% repeatability of the cone shape. The

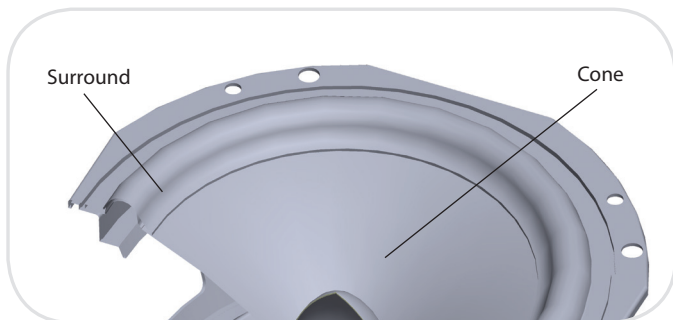

surrounds- the rubber rolls on the side of the cones that define the cones' movement – were optimized with an advanced mass balancing technique, simulated by FEA software and tested by ear in listening sessions.

A Series

L o u d s p e a k e r s

Cabinet Design

The speaker cabinet, while superficially seeming to be the “pretty face” of the system, is an acoustic component nearly as critical as the speaker drivers. The cabinet performs two key acoustic functions: acting as a tuned chamber magnifying the woofer’s sound output, and providing a clean acoustic baffle, or surface, so the driver’s sound is transmitted to the room (and your ears) in purest form. In both cases, if the cabinet is flimsy or poorly designed, reproduced music won’t sound natural and clear.

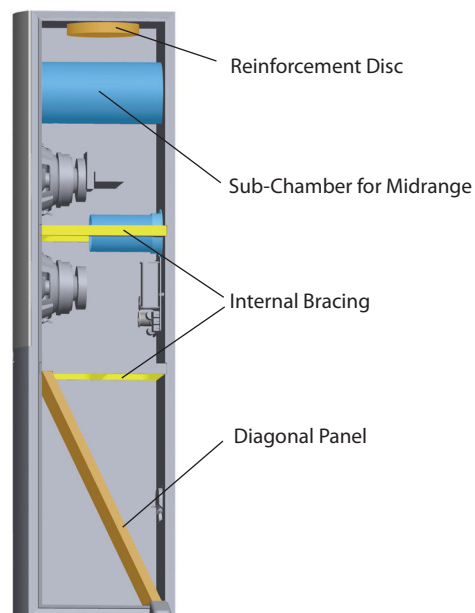

In the first function, all A Series models use a tuned resonant port design to extend and solidify the bass output from the woofer. The cabinet tuning is designed for a smooth roll-off (at the lowest frequencies) which makes the speakers more room-friendly. The design also avoids unwanted vibrations and resonances: all models incorporate bracing to provide structure, and the A 25, A 26, A 250, and A 360 use a wooden reinforcement disc that essentially doubles the acoustic thickness of the top panel to 1.4 inches (36mm) thick. This reinforcement disc minimizes extraneous sound radiation and resulting distortion from the top panel. The result: a cleaner sound and better stereo image compared to more conventional cabinet designs.

The A 250 and A 360 floorstanding models received special design features, including internal braces and an innovative diagonal panel which eliminate the tendency to have unwanted “organ pipe” resonances that plague some floorstanding speaker designs. In these heavily braced floorstanding models, the lower midrange (human voice range) frequency response is very smooth compared to a cabinet with no divider, resulting in much better sound quality. Even the port position in the A 250 and A 360 has been optimized, so the ports output is equally energized by both woofers, resulting in clean extended bass.

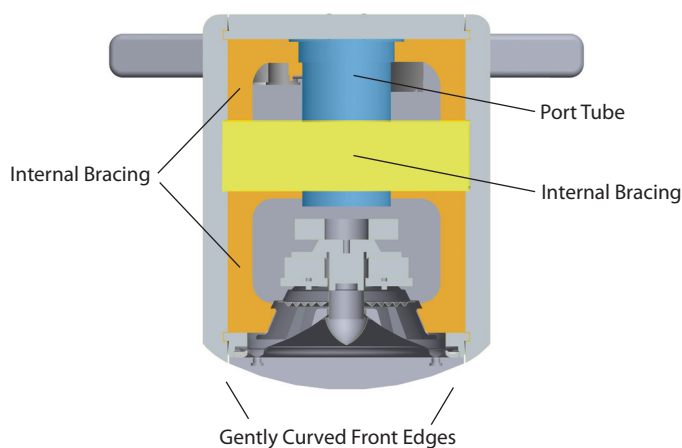

In the second function, the A Series cabinets place the drivers on a clean front panel surface. At first glance, the gently rounded front edges and hardware-free front panel (made possible by magnetic attachment of the grille) would seem to be for appearances only. But these smoothing features reduce diffraction from the drivers, cleaning up the radiated sound, a benefit to flat frequency response and good stereo imaging.

Crossover Design

If the drivers are the heart, and the cabinet the body, the crossover is the soul of the speaker. The crossover is an electronic circuit that directs the appropriate frequency range to each speaker driver. If the crossover is designed poorly, the speaker sounds bad. With a well-designed crossover, the speaker is magical – delivering all the attributes mentioned at the beginning of this paper. The key is to divide the acoustic range so the right amount of acoustic energy comes from each driver, evenly across the frequency spectrum, and with an even coverage around the listening space (your room). All the parts in the crossover – resistors, capacitors, inductors – have an effect on the sound, and choosing the right parts will deliver the “magic.” Special elements such as low loss film capacitors and low distortion laminated silicon steel core inductors have been used at all critical areas. On some models, only the combination of two different capacitors in parallel gave the sound character matching our goal. We even go so far as to optimize the location of the components relative to each other, to minimize electromagnetic interaction that might mar the sound!

A 360 frequency response, showing individual drivers (colors) and final response (black)

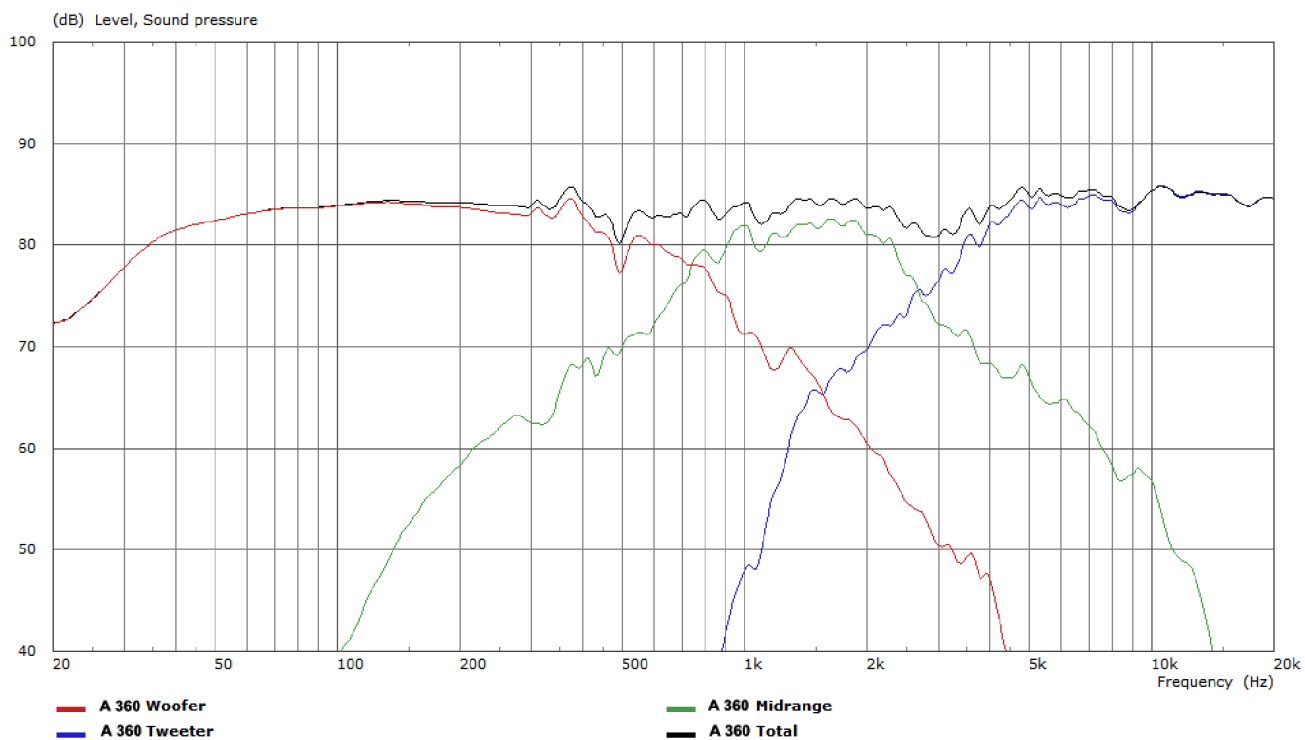

A Series Subwoofers

For the listener building a potent home theater, or demanding the weight and authority of the lowest musical tones, the A Series subwoofers deliver tremendous energy. So how does Boston Acoustics apply its Play Smart design philosophy to make a subwoofer truly special? The most important electro-acoustic qualities in a subwoofer design are (a) the precision of bass sound reproduction from the input signal, and (b) the ability of the sub to blend seamlessly with the sound of the main speakers.

The sonic precision of the ASW models begins with the driver element: Both models incorporate a 10" woofer with a Deep Channel® Design (DCD) magnet structure, a voice coil with generous thermal capacity, and stiff treated organic pulp cone. The top model ASW 650 incorporates a new woofer design – a design that differs from competitors in the geometry and physics of the woofer design. All woofers are asymmetrical front-to-back, as they have the cone at the front, voice coil, in the middle and, magnet structure to the middle and back. Even with this structural asymmetry, careful design will allow the moving voice coil to travel in the most linear fashion through the most consistent magnetic field – resulting not only in low distortion, but also the greatest dynamics, as this low distortion is maintained up to much higher sound levels compared with a design that is not optimized. Just like balancing the moving parts of a high end sports car suspension, Boston engineers tune the driver's movement, both with tools like the Klippel R&D System, and also by ear, using music and movies.

The ASW 650 brings a new enhancement to its sonic precision, a switched mode power supply. The power supply is the electrical reserve, fed by the AC mains plug from your wall, providing the electrical power for the subwoofer's amplifier. In electrical engineering terms, this new power supply is very "stiff," meaning that it maintains its reserve even during the greatest musical demands. Compared with other designs, where a repeated bass tone or movie effect would deplete the power supply, the new ASW 650 power supply remains firm – the result is not only lower distortion, but more consistent performance during extended loud passages. And, the new ASW 650 power supply design adds two more Play Smart user benefits. First, the ASW 650 is rear-panel switchable for 120V or 230V use, a handy feature for anyone who may move to a new region of the world with a different line voltage supply. Second, the ASW 650 is greener than most competitors, sipping less electricity at idle or during quiet music.

ASW 650

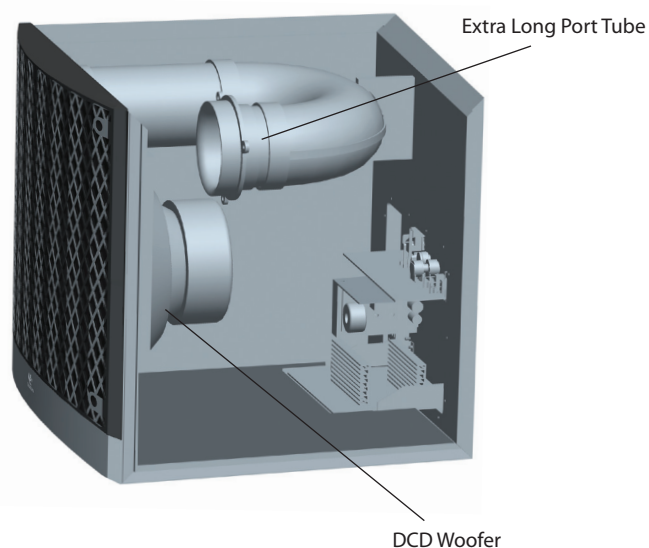

Continued

A Series

L o u d s p e a k e r s

These self amplified models permit our engineers to add a fourth element to the design mix, active electronics. Boston subwoofers include BassTrac®, a proprietary circuit that maximizes bass output while at the same time avoiding overload – so these subwoofers can play loud and low all day without distress. BassTrac works by monitoring the incoming acoustic signal and modulating the amplifier's output level to keep sound levels – and distortion – under control.

In order to meet the second Play Smart design objective for our subwoofers – to blend seamlessly with the main speakers, Boston engineers included a variety of connection and adjustment options: Each subwoofer includes two types of input connections. The LFE (“Low Frequency Effects”) input is designed for use with electronics such as Audio Video Receivers with their own crossover control. The LFE input bypasses the subwoofer's own crossover control, and is the best choice for home theater setups. The Left and Right inputs are a good choice for stereo systems, where the listener may optimize the crossover (dividing frequency) between subwoofer and main speaker by using adjusting the crossover knob.

Both ASW models incorporate a 4th-order (24 dB/octave) adjustable low pass filter, allowing a sharp cut-off the subwoofer's response as a sound's frequency increases out of the subwoofer range. The benefit of such a sharp filter is that the user may tune the sub's output to match the bass extension of the main speakers – for instance if the main speakers themselves have good bass extension, then the subwoofer may be set to produce only the lowest tones. If the user owns a smaller monitor speaker, such as the A 23 or A 25, then the subwoofer may be set by ear for a much higher cut-off, giving a clean balance across the whole frequency range



ASW 650



ASW 250